

BELUGA

Open Channel Digital Acoustic Flow Meter Sensor



BELUGA 45° & BELUGA 20°

The BELUGA is the newest digital ACOUSTIC area/velocity flow meter sensor for open channel flow measurements from FLOW-TRONIC. It is suitable for partially filled pipes and surcharged pipes without primary devices such as flumes or weirs.

This sensor combines advanced digital Doppler ultrasonic velocity sensing technology with most modern and powerful DSP processor technology, allowing real-time spectral analysis of the velocity distribution through the cross-sectional area.

The BELUGA becomes a powerful flow measuring system when combined with a level sensor and a monitor for permanent monitoring (which display flow rate, velocity, level and much more) or a logger for portable monitoring from the IFQ series: IFQ MONITOR or IFQ LOGGER.

Technical Specifications

Velocity Measurement

Method	Ultrasonic Doppler
Frequency	1 MHz
Range	-2 to +6 m/s (-6.56 to +19.68 ft/s)
Measurement	Bi-directional
Accuracy	Better than 1% + zero stability (according to hydraulic and installation conditions compliance)
Zero Stability	$\pm 0,01$ m/s (± 0.03 ft/s)
Resolution	0,001 m/s (0.03 ft/s)

Optional Combined Level Measurement (Ultrasonic)

Method	Ultrasonic pulsed echo
Range	0,00 to 1,75 m (0 to 5.74 ft) (with RAV-0002/ULS-02) 0,00 to 5,75 m (0 to 18.86 ft) (with RAV-0006/ULS-06)
Accuracy	$\pm 0,3\%$ of reading (with RAV-0002/ULS-02) $\pm 0,2\%$ of reading (with RAV-0006/ULS-06) Includes non-linearity + hysteresis
Temp. Error	Max. 0,04%/K
Resolution	1 mm (0.04'')

Optional Combined Level Measurement (Radar)

Method	Non-contact Pulsed Radar
Range	0,00 to 15 m (0 to 49.21 ft)
Accuracy	± 2 mm (0.08'') of reading
Resolution	1 mm (0.04'')

Optional Separate Level Measurement

Method	Any 4-20 mA loop powered sensor
--------	---------------------------------

Flow Measurement

Method	Conversion from measured velocity to average velocity based on integrated spectral analysis of the velocity distribution in the cross-sectional area. Conversion of water level and pipe size to fluid area. Multiplication of fluid area by average velocity to obtain the flow rate.
--------	---

Communication

RS-485 communication port with Modbus ASCII slave communication protocol.

Outputs (optional)

4-20 mA	1 for validated velocity (vQP) or validated velocity including median filter (vQPMF).
---------	---

Internal Temperature Measurement

Method	Internal temperature sensor
Range	-40°C to +80°C (-40° to +176°F)



FLOW-TRONIC

www.flow-tronic.com

Chemin des Tilleuls 32 | 4840 Welkenraedt | BELGIUM
Tel.: +32 (0)87 899 799 | E-mail: info@flow-tronic.com

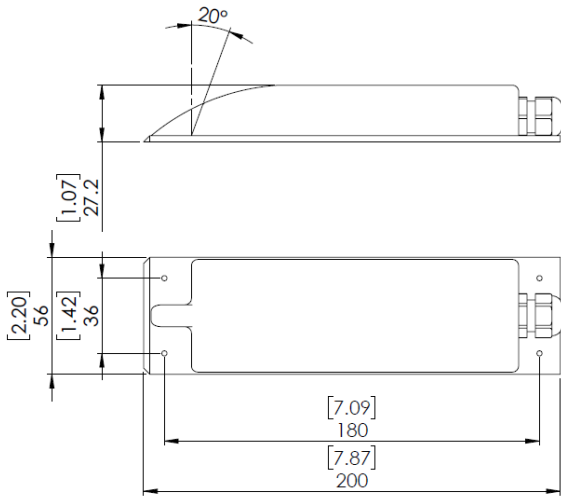

BELUGA 20°

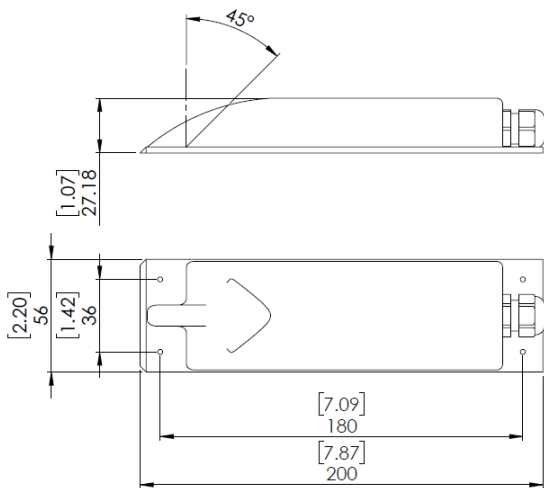

BELUGA 45°

Technical Specifications

Material & Dimensions

Enclosure	HIGH IMPACT PVC-C
Dimensions	190 mm L, 48 mm W, 28 mm H (7.48" L, 1.89" W, 1.10" H)
Weight	0,26 kg (0.57 lb)(without cable, level sensor and mounting accessories)
Protection rate	IP68

Environmental Conditions

Operating temperature range	-20°C to +50°C (-4 to +122°F)
Storage temperature range	-30°C to +60°C (-22 to +140°F)

Supply Voltage Required

4 to 26 VDC (max. 130 mA @ 12 VDC) or supplied by IFQ MONITOR or IFQ LOGGER

Power Consumption	Sleep: 60 mA @ 12 VDC Measuring: 120 mA @ 12 VDC
-------------------	---

Certifications

Sensor	CE
--------	----

Sensor Cable

Material	Polyurethane jacketed
Length	Standard: 10 m (32.81 ft) Optional: 20 m (65.62 ft), 30 m (98.43 ft) or length as needed up to 300 m (984.25 ft)



FLOW-TRONIC

www.flow-tronic.com

*Specifications are subject to change without notice
Updated: February 2022*

Chemin des Tilleuls 32 | 4840 Welkenraedt | BELGIUM
Tel.: +32 (0)87 899 799 | E-mail: info@flow-tronic.com